

MAQUINA	DESCRIPCION
QCG6B50C	CLAVADORA CORGRAP 6/50C 2N1

DESDE FECHA	01/01/2013
HASTA FECHA	31/12/2099

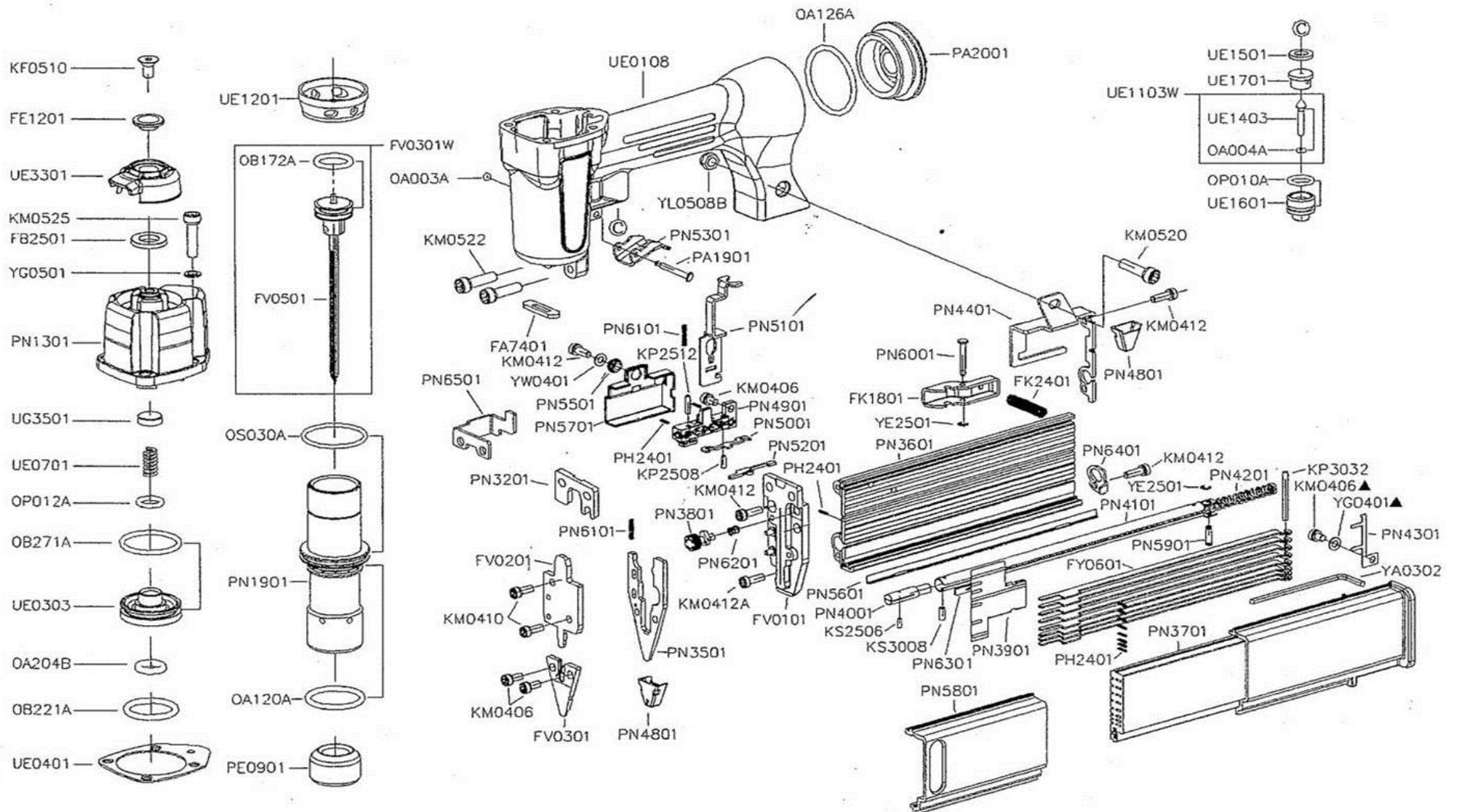



MAQUINA	DESCRIPCION	DESDE FECHA	01/01/2013
QCG6B50C	CLAVADORA CORGRAP 6/50C 2N1	HASTA FECHA	31/12/2099

RECAMBIO	DESCRIPCION	CANTIDAD	POSICION
RAPFA7401 (FA7401)	BOQUILLA FA7401	1	FA7401
RAPFB2501 (FB2501)	TOPE FB2501	1	FB2501
RAPFE1201 (FE1201)	JUNTA FE1201	1	FE1201
RAPFK1801 (FK1801)	CIERRE FK1801	1	FK1801
RAPFK2401 (FK2401)	MUELLE FK2401	1	FK2401
RAPFV0101 (FV0101)	PLATO FV0101	1	FV0101
RAPFV0201 (FV0201)	PLATO FV0201	1	FV0201
RAPFV0301 (FV0301)	PLATO FV0301	1	FV0301
RAPFV0302W (FV0301W)	CUCHILLA FV0302W	1	FV0301W
RAPFV0301W (FV0501)	GUÍA FV0301W	1	FV0501
RAPFY0601 (FY0601)	PLATO FY0601	8	FY0601
RAPKF0510 (KF0510)	PERNO KF0510	1	KF0510
RAPKM0406 (KM0406)	TORNILLO KM0406	3	KM0406
RAPKM0410 (KM0410)	PERNO KM0410	2	KM0410
RAPKM0412 (KM0412)	TORNILLO KM0412	4	KM0412
RAPKM0412A (KM0412A)	PERNO KM0412A	1	KM0412A
RAPKM0520 (KM0520)	PERNO KM0520	1	KM0520
RAPKM0522 (KM0522)	PERNO KM0522	2	KM0522
RAPKM0525 (KM0525)	PERNO KM0525	4	KM0525
RAPKP2508 (KP2508)	PASADOR KP2508	1	KP2508
RAPKP2512 (KP2512)	PASADOR KP2512	1	KP2512
RAPKP3032 (KP3032)	PASADOR KP3032	1	KP3032
RAPKS2506 (KS2506)	PASADOR KS2506	1	KS2506
RAPKS3008 (KS3008)	PASADOR KS3008	1	KS3008
RAPOA003A (OA003A)	ANILLO TÓRICO OA003A	1	OA003A
RAPOA004A (OA004A)	ANILLO TÓRICO OA004A	1	OA004A
RAPOA120A (OA120A)	ANILLO TÓRICO OA120A	1	OA120A



MAQUINA	DESCRIPCION	DESDE FECHA	01/01/2013
QCG6B50C	CLAVADORA CORGRAP 6/50C 2N1	HASTA FECHA	31/12/2099

RECAMBIO	DESCRIPCION	CANTIDAD	POSICION
RAPOA126A (OA126A)	ANILLO TÓRICO OA126A	1	OA126A
RAPOA204B (OA204B)	ANILLO TÓRICO OA204B	1	OA204B
RAPOB172A (OB172A)	ANILLO TÓRICO OB172A	1	OB172A
RAPOB221A (OB221A)	ANILLO TÓRICO OB221A	1	OB221A
RAPOB271A (OB271A)	ANILLO TÓRICO OB271A	1	OB271A
RAPOP010A (OP010A)	ANILLO TÓRICO OP010A	1	OP010A
RAPOP012A (OP012A)	ANILLO TÓRICO OP012A	1	OP012A
RAPOS030A (OS030A)	ANILLO TÓRICO OS030A	1	OS030A
RAPPA1901 (PA1901)	PASADOR PA1901	1	PA1901
RAPPA2001 (PA2001)	TAPA PA2001	1	PA2001
RAPPE0901 (PE0901)	AMORTIGUADOR PE0901	1	PE0901
RAPPH2401 (PH2401)	MUELLE PH2401	11	PH2401
RAPPN1301 (PN1301)	TAPA PN1301	1	PN1301
RAPPN1901 (PN1901)	CILINDRO PN1901	1	PN1901
RAPPN3201 (PN3201)	PLATO PN3201	1	PN3201
RAPPN3501 (PN3501)	PLATO PN3501	1	PN3501
RAPPN3601 (PN3601)	SOPORTE PN3601	1	PN3601
RAPPN3701 (PN3701)	TAPA PN3701	1	PN3701
RAPPN3801 (PN3801)	RODILLO PN3801	1	PN3801
RAPPN3901 (PN3901)	EMPUJADOR PN3901	1	PN3901
RAPPN4001 (PN4001)	PASADOR PN4001	1	PN4001
RAPPN4101 (PN4101)	SOPORTE PN4101	1	PN4101
RAPPN4201 (PN4201)	MUELLE PN4201	1	PN4201
RAPPN4301 (PN4301)	PLATO PN4301	1	PN4301
RAPPN4401 (PN4401)	SOPORTE PN4401	1	PN4401
RAPPN4801 (PN4801)	GRUESO PN4801	2	PN4801
RAPPN4901 (PN4901)	SEGURO PN4901	1	PN4901



MAQUINA	DESCRIPCION	DESDE FECHA	01/01/2013
QCG6B50C	CLAVADORA CORGRAP 6/50C 2N1	HASTA FECHA	31/12/2099

RECAMBIO	DESCRIPCION	CANTIDAD	POSICION
RAPPN5001 (PN5001)	PLATO PN5001	1	PN5001
RAPPN5101 (PN5101)	SEGURO PN5101	1	PN5101
RAPPN5201 (PN5201)	PLATO PN5201	1	PN5201
RAPPN5301 (PN5301)	GATILLO PN5301	1	PN5301
RAPPN5501 (PN5501)	EJE PN5501	1	PN5501
RAPPN5601 (PN5601)	LAMINA PN5601	1	PN5601
RAPPN5701 (PN5701)	TAPA PN5701	1	PN5701
RAPPN5801 (PN5801)	TAPA PN5801	1	PN5801
RAPPN5901 (PN5901)	PASADOR PN5901	1	PN5901
RAPPN6001 (PN6001)	PASADOR PN6001	1	PN6001
RAPPN6101 (PN6101)	MUELLE PN6101	2	PN6101
RAPPN6201 (PN6201)	MUELLE PN6201	1	PN6201
RAPPN6301 (PN6301)	PLATO PN6301	1	PN6301
RAPPN6401 (PN6401)	CARGADOR PN6401	1	PN6401
RAPPN6501 (PN6501)	TOPE PN6501	1	PN6501
RAPUE0108 (UE0108)	CUERPO UE0108	1	UE0108
RAPUE0303 (UE0303)	PISTÓN UE0303	1	UE0303
RAPUE0401 (UE0401)	JUNTA UE0401	1	UE0401
RAPUE0701 (UE0701)	MUELLE UE0701	1	UE0701
RAPUE1103W (UE1103W)	EJE UE1103W	1	UE1103W
RAPUE1201 (UE1201)	COLLAR UE1201	1	UE1201
RAPUE1403 (UE1403)	VÁLVULA UE1403	1	UE1403
RAPUE1501 (UE1501)	JUNTA UE1501	1	UE1501
RAPUE1601 (UE1601)	GUÍA UE1601	1	UE1601
RAPUE1701 (UE1701)	SOPORTE UE1701	1	UE1701
RAPUE3301 (UE3301)	TAPA UE3301	1	UE3301
RAPUG3501 (UG3501)	TOPE UG3501	1	UG3501



MAQUINA	DESCRIPCION	DESDE FECHA	01/01/2013
QCG6B50C	CLAVADORA CORGRAP 6/50C 2N1	HASTA FECHA	31/12/2099

RECAMBIO	DESCRIPCION	CANTIDAD	POSICION
RAPYA0302 (YA0302)	LLAVE ALLEN YA0302	1	YA0302
RAPYE2501 (YE2501)	CER-CLIP YE2501	2	YE2501
RAPYG0501 (YG0501)	ARANDELA RAPYG0501	4	YG0501
RAPYL0508B (YL0508B)	TUERCA YL0508B	1	YL0508B
RAPYW0401 (YW0401)	ARANDELA YW0401	1	YW0401